

TXT DESIGN BY AS DUAS POR TRÊS + DIGITALAB



TECHNOLOGY

TEXTURING

THROUGH EMOTIONAL DESIGN

TECHXTURE is merging seamlessly technology and textures to generate extraordinary design objects.
A product design brand that blurs the boundary line among art, design, technology and user experiences.



TXT COFFEE TABLE

How can we materialize an abstract concept of a brand in a design piece? The TXT coffee table is an object that reflects the main concepts of the brand. NOIXE texture was created as a brand ADN, a unique pattern that derives from the conceptual principles of brand philosophy. This digital noise is created using a generative algorithm that creates multiple variations from the basic principle. A special Engineering stone was the material chosen to materialize the idea due to its technical properties, strength and easy maintenance.

All parts are made of the same material contributing to a perfect technical and aesthetic harmony.



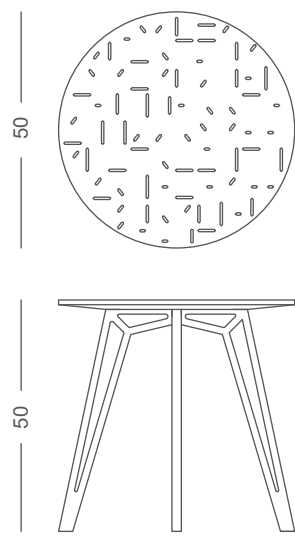
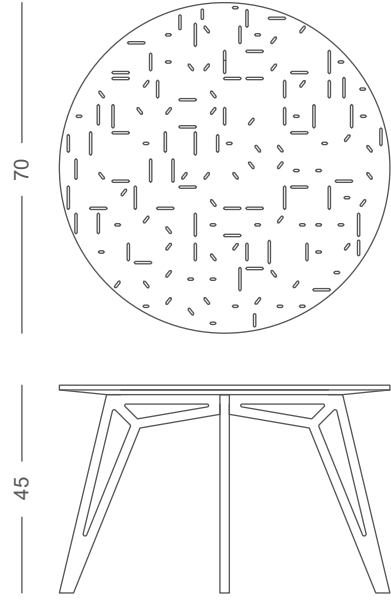
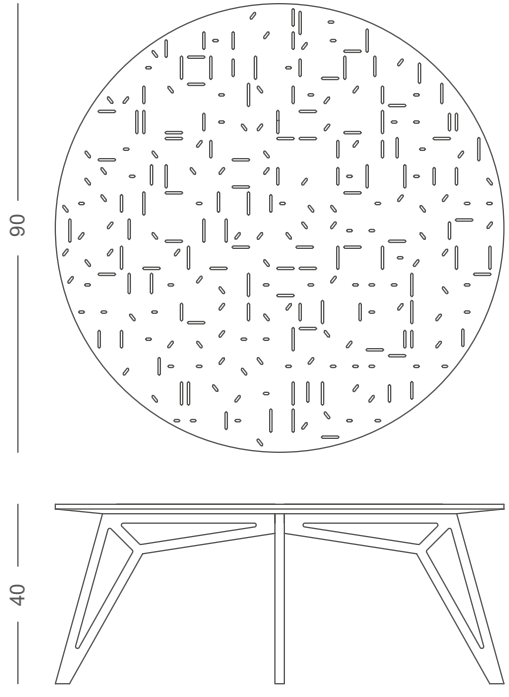

NOIXE, the noise pattern, developed specifically for techxture. A visual detail that appeals to our senses.







Stone as structure, noise as natural pattern. Exploratory design.

NAME TXT

CODE M
White Snow 10T2020046
Graphite 10T2020032
Limestone 10T2020045

L
White Snow 10T2020031
Graphite 10T2020044
Limestone 10T2020045

S
White Snow 10T2020047
Graphite 10T2020048
Limestone 10T2020049

TIPOLOGY Coffee table

MATERIALS Engineering stone

COLOURS AND FINISHES



White snow



Graphite



Orange



Limestone

SIZES M_D= 90 H= 40 cm
L_D= 70 H= 45 cm
S_D= 50 H= 50 cm

DESIGN BY Às duas por três
DIGITALAB

BRAND BY



TECHXTURE.PT